



**ALLIED MACHINE
& ENGINEERING**

WOHLHAUPTER®

Holemaking Solutions for Today's Manufacturing



Boring



Reaming



Burnishing



Threading



Specials



BT-A Drill

▶ **DRILLING**

BTA-STS (Single Tube System) Machining

SECTION

A93

BT-A Drill

BT-A Drill

BTA (STS) Deep Hole Machining System

► **Diameter Range:** 12.98 mm - 47.82 mm (0.5110" - 1.8829")



Material Ejection with Efficiency

The BT-A drill (using the single tube system or STS) conquers deep hole applications in ways other drills simply cannot. The internal ejection system flushes chips and debris from the hole with no interference to the cutting process.

By utilising the countless advantages of the T-A® drill insert, the BT-A design significantly increases penetration rates over brazed heads and traditional gun drills. A specific BT geometry has also been developed to increase productivity in these types of drilling applications.

Excellent hole size and finish.	Optimises chip evacuation.	Up to 2x the penetration rate of traditional BTA heads.
---------------------------------	----------------------------	--

Applicable Industries



Your safety and the safety of others is very important. This catalogue contains important safety messages. Always read and follow all safety precautions.



This triangle is a safety hazard symbol. It alerts you to potential safety hazards that can cause tool failure and serious injury.

When you see this symbol in the catalogue, look for a related safety message that may be near this triangle or referred to in the nearby text.

There are safety signal words also used in the catalogue. Safety messages follow these words.

WARNING

WARNING (shown above) means that failure to follow the precautions in this message could result in tool failure and serious injury.

NOTICE means that failure to follow the precautions in this message could result in damage to the tool or machine but not result in personal injury.

NOTE and **IMPORTANT** are also used. These are important that you read and follow but are not safety-related.

Visit www.alliedmachine.com for the most up-to-date information and procedures.

BT-A Drilling System Contents

Reference Icons

The following icons will appear throughout the catalogue to help you navigate between products.

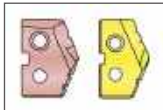

T-A® Inserts
Refers to the range of inserts that connect with the corresponding holders

Introduction Information

System Overview 2
Product Nomenclature 3

T-A Drill Series

0 Series 4
1 Series 5
2 Series 6
3 Series 7

Series	Diameter Range	
	Metric (mm)	Imperial (inch)
0	12.98 - 17.67	0.5110 - 0.6959
1	17.53 - 24.40	0.6900 - 0.9609
2	24.41 - 35.06	0.9610 - 1.3809
3	34.37 - 47.82	1.3530 - 1.8829



System Overview

BTA Machining

BTA machining is the reverse of typical gun drilling systems. The BT-A drill is a drill head consisting of a holder body and a replaceable tip T-A® insert. The drill head threads into an STS (single tube system) cylindrical tube with a diameter smaller than the drill head. The difference in diameter forms an annular area between the hole and the tube OD. This allows high-volume coolant to be directed to the cutting edge.

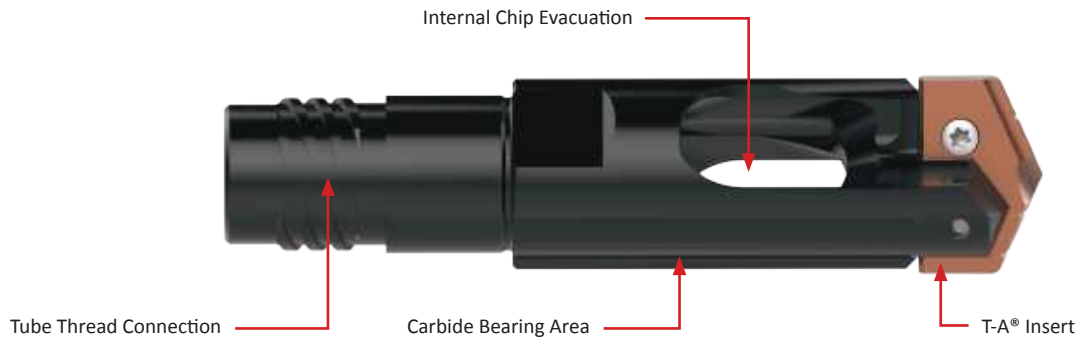

T-A Insert: BT-A Geometry (-BT)

- Low thrust web geometry reduces Z-axis requirements.
- Lip geometry identical to the tiny chip (-TC) for improved chip formation.
- Polished cutting surface eliminates material buildup.



- ✓ **Improve hole straightness**
with the laser clad bearing area
- ✓ **Eliminate the need for sharpening**
with replaceable cutting edges
- ✓ **Reduce your inventory**
with the replaceable T-A® feature
- ✓ **Compatibility**
heads are compatible with standard BTA-STS systems
- ✓ **Balanced cutting forces**
- ✓ **Patented design**

BT-A Single Tube System

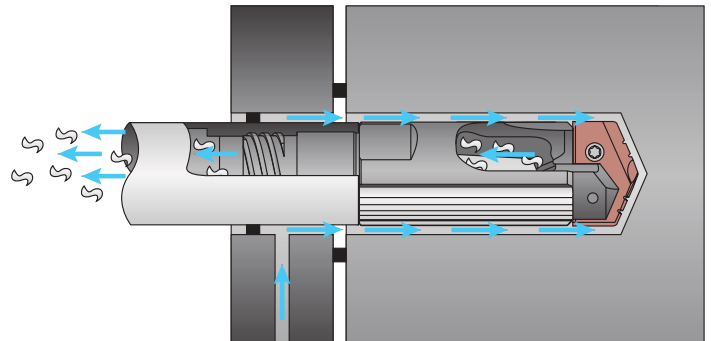

BT-A Double Tube (Ejector) System (Quoted Special)

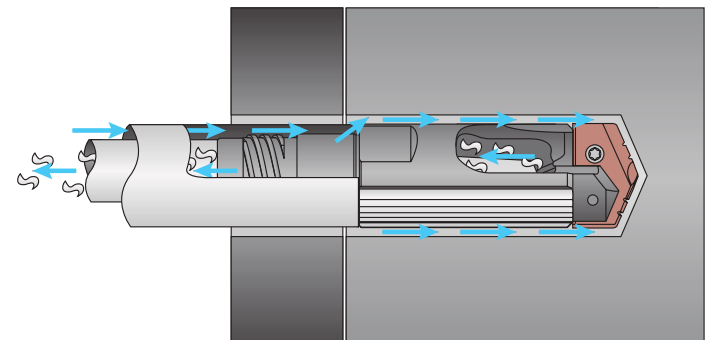

2x INCREASE in penetration rates over traditional BTA heads



Product Nomenclature

BT-A Drill Holders

BTA2	804	1.1299
1	2	3

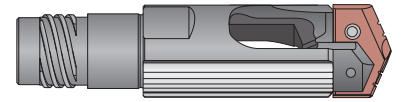

1. BT-A Drill T-A [®] Insert Series
BTA0 = 0 series T-A insert
BTA1 = 1 series T-A insert
BTA2 = 2 series T-A insert
BTA3 = 3 series T-A insert

2. Tube Size		
794	800	806
795	801	807
796	802	808
797	803	809
798	804	810
799	805	811

3. Diameter
25.00 = Metric
0.7344 = Inch

Reference Key

Symbol	Attribute
D_1	Drill insert range
L_1	Overall length
L_3	Holder reference length
L_7	Shank length

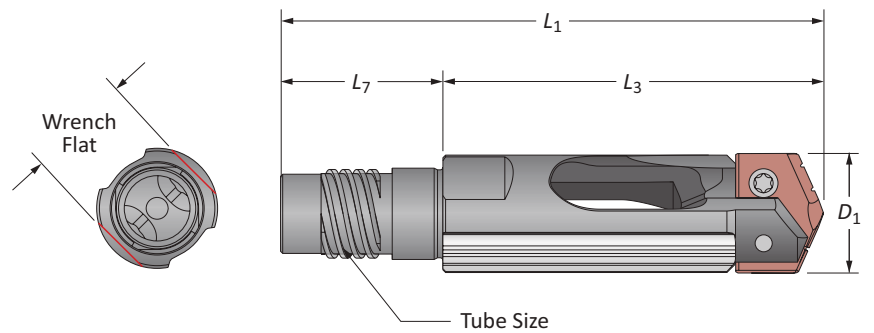

BT-A Drill Tubes

BTAT	804	63
1	2	3

1. BT-A Drill T-A [®] Insert Series
BTAT = BT-A Tube

2. Tube Size		
794	800	806
795	801	807
796	802	808
797	803	809
798	804	810
799	805	811

3. Length
63 = Standard
102 = Long

Reference Key

Symbol	Attribute
D_1	Body diameter
ID_1	Internal diameter
L_1	Overall length

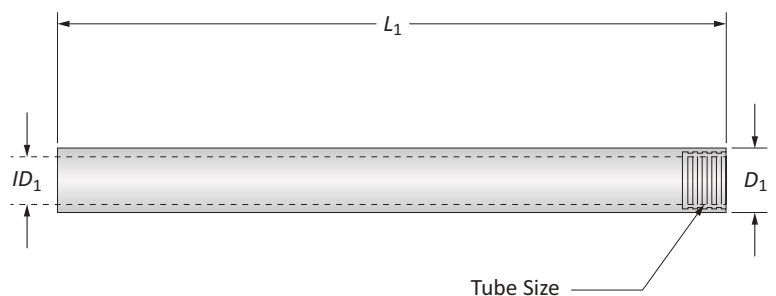



BT-A Drill Holders

0 Series | Diameter Range: 12.98 mm - 17.67 mm (0.5110" - 0.6959")

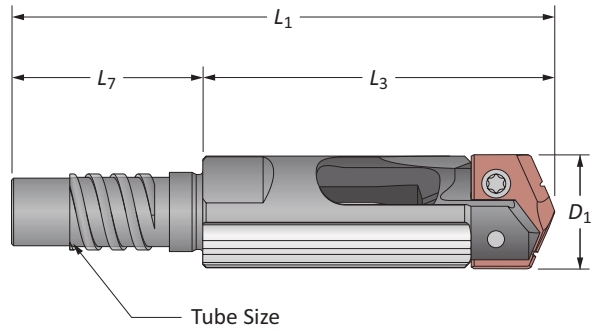
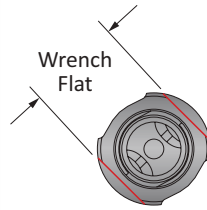

Tube Size	D ₁	Holder			Part No.	T-A® Insert	Wrench Flat (mm)	
		L ₃	L ₁	L ₇				
m	794	12.98 - 13.61	43.4	66.4	23	BTA0-794-XX.XX	1C10H-XXXX-BT	11
	795	13.62 - 14.63	44.6	67.6	23	BTA0-795-XX.XX	1C10H-XXXX-BT	12
	796	14.64 - 15.62	45.9	69.9	24	BTA0-796-XX.XX	1C10H-XXXX-BT	13
	797	15.63 - 16.71	45.9	69.9	24	BTA0-797-XX.XX	1C10H-XXXX-BT	14
	798	16.72 - 17.67	45.3	69.3	24	BTA0-798-XX.XX	1C10H-XXXX-BT	15
i	794	0.5110 - 0.5359	1-45/64	2-39/64	29/32	BTA0-794-X.XXXX	1C10H-XXXX-BT	11
	795	0.5360 - 0.5759	1-3/4	2-21/32	29/32	BTA0-795-X.XXXX	1C10H-XXXX-BT	12
	796	0.5760 - 0.6149	1-13/16	2-3/4	61/64	BTA0-796-X.XXXX	1C10H-XXXX-BT	13
	797	0.6150 - 0.6579	1-13/16	2-3/4	61/64	BTA0-797-X.XXXX	1C10H-XXXX-BT	14
	798	0.6580 - 0.6959	1-25/32	2-47/64	61/64	BTA0-798-X.XXXX	1C10H-XXXX-BT	15

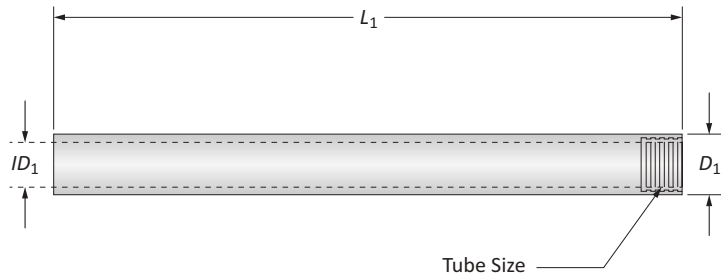

Tube Size	Tube			Part No.	
	D ₁	ID ₁	L ₁		
m	794	11.00	7.00	1600	BTAT794-63
	794	11.00	7.00	2591	BTAT794-102
	795	12.00	8.00	1600	BTAT795-63
	795	12.00	8.00	2591	BTAT795-102
	796	13.00	8.50	1600	BTAT796-63
	796	13.00	8.50	2591	BTAT796-102
	797	14.00	9.00	1600	BTAT797-63
	797	14.00	9.00	2591	BTAT797-102
	798	15.00	10.00	1600	BTAT798-63
	798	15.00	10.00	2591	BTAT798-102
i	794	0.433	0.276	63	BTAT794-63
	794	0.433	0.276	102	BTAT794-102
	795	0.472	0.315	63	BTAT795-63
	795	0.472	0.315	102	BTAT795-102
	796	0.512	0.335	63	BTAT796-63
	796	0.512	0.335	102	BTAT796-102
	797	0.551	0.354	63	BTAT797-63
	797	0.551	0.354	102	BTAT797-102
	798	0.591	0.394	63	BTAT798-63
	798	0.591	0.394	102	BTAT798-102

Section A30

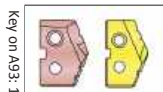

m = Metric (mm)
i = Imperial (in)



BT-A Drill Holders

1 Series | Diameter Range: 17.53 mm - 24.40 mm (0.6909" - 0.9609")

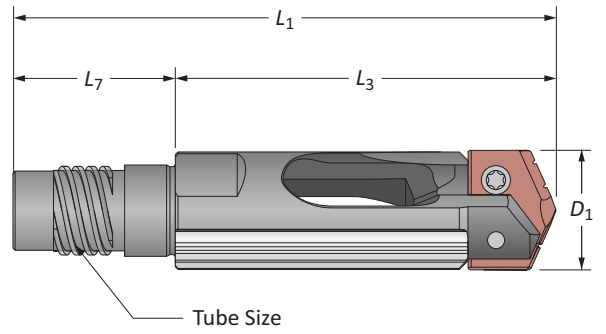
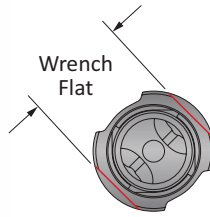

Tube Size	Holder				Part No.	T-A® Insert	Wrench Flat (mm)	
	D ₁	L ₃	L ₁	L ₇				
m	799	17.53 - 18.92	58.2	83.2	25	BTA1-799-XX.XX	1C11H-XXXX-BT	16
	800	18.93 - 20.01	58.8	86.8	28	BTA1-800-XX.XX	1C11H-XXXX-BT	17
	801	20.02 - 21.81	59.4	89.9	30.5	BTA1-801-XX.XX	1C11H-XXXX-BT	18
	802	21.82 - 24.10	60.7	93.7	33	BTA1-802-XX.XX	1C11H-XXXX-BT	19
	803	24.11 - 24.40	63.9	96.9	33	BTA1-803-XX.XX	1C11H-XXXX-BT	21
i	799	0.6900 - 0.7449	2-15/64	3-9/32	63/64	BTA1-799-X.XXXX	1C11H-XXXX-BT	16
	800	0.7450 - 0.7879	2-5/16	3-27/64	1-7/64	BTA1-800-X.XXXX	1C11H-XXXX-BT	17
	801	0.7880 - 0.8589	2-11/32	3-35/64	1-13/64	BTA1-801-X.XXXX	1C11H-XXXX-BT	18
	802	0.8590 - 0.9489	2-25/64	3-11/16	1-19/64	BTA1-802-X.XXXX	1C11H-XXXX-BT	19
	803	0.9490 - 0.9609	2-33/64	3-13/16	1-19/64	BTA1-803-X.XXXX	1C11H-XXXX-BT	21

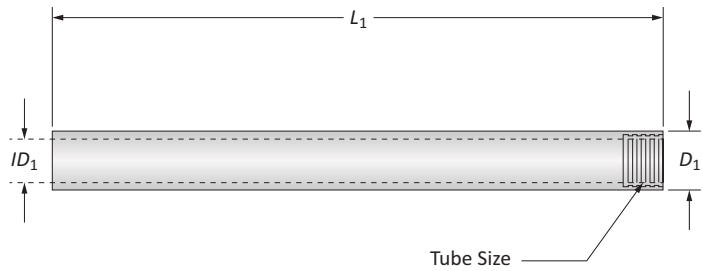

Tube Size	Tube			Part No.	
	D ₁	ID ₁	L ₁		
m	799	16.00	10.50	1600	BTAT799-63
	799	16.00	10.50	2591	BTAT799-102
	800	17.00	11.50	1600	BTAT800-63
	800	17.00	11.50	2591	BTAT800-102
	801	18.00	12.00	1600	BTAT801-63
	801	18.00	12.00	2591	BTAT801-102
	802	20.00	13.00	1600	BTAT802-63
	802	20.00	13.00	2591	BTAT802-102
	803	22.00	14.00	1600	BTAT803-63
	803	22.00	14.00	2591	BTAT803-102
i	799	0.630	0.413	63	BTAT799-63
	799	0.630	0.413	102	BTAT799-102
	800	0.669	0.453	63	BTAT800-63
	800	0.669	0.453	102	BTAT800-102
	801	0.709	0.472	63	BTAT801-63
	801	0.709	0.472	102	BTAT801-102
	802	0.787	0.512	63	BTAT802-63
	802	0.787	0.512	102	BTAT802-102
	803	0.866	0.551	63	BTAT803-63
	803	0.866	0.551	102	BTAT803-102

Section A30

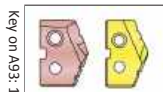

m = Metric (mm)
i = Imperial (in)



BT-A Drill Holders

2 Series | Diameter Range: 24.41 mm - 35.06 mm (0.9610" - 1.3809")

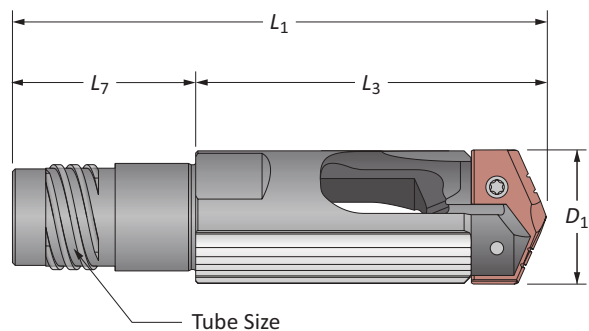
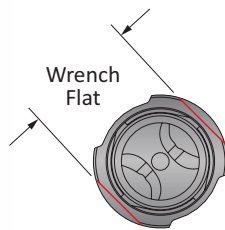

Tube Size	Holder				Part No.	T-A® Insert	Wrench Flat (mm)	
	D_1	L_3	L_1	L_7				
m	803	24.41 - 26.41	78.5	111.5	33	BTA2-803-XX.XX	1C12H-XXXX-BT	21
	804	26.42 - 28.70	75.9	103.9	28	BTA2-804-XX.XX	1C12H-XXXX-BT	22
	805	28.71 - 31.01	75.4	111.4	36	BTA2-805-XX.XX	1C12H-XXXX-BT	25
	806	31.02 - 33.32	77.9	113.8	36	BTA2-806-XX.XX	1C12H-XXXX-BT	27
	807	33.33 - 35.06	77.9	113.8	36	BTA2-807-XX.XX	1C12H-XXXX-BT	30
i	803	0.9610 - 1.0399	3-3/32	4-25/64	1-19/64	BTA2-803-X.XXXX	1C12H-XXXX-BT	21
	804	1.0400 - 1.1299	3	4-3/32	1-7/64	BTA2-804-X.XXXX	1C12H-XXXX-BT	22
	805	1.1300 - 1.2209	2-31/32	4-25/64	1-27/64	BTA2-805-X.XXXX	1C12H-XXXX-BT	25
	806	1.2210 - 1.3119	3-1/16	4-31/64	1-27/64	BTA2-806-X.XXXX	1C12H-XXXX-BT	27
	807	1.3120 - 1.3809	3-1/16	4-31/64	1-27/64	BTA2-807-X.XXXX	1C12H-XXXX-BT	30

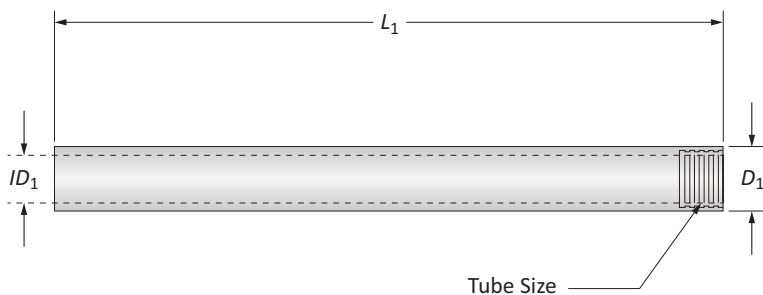

Tube Size	Tube			Part No.	
	D_1	ID_1	L_1		
m	803	22.00	14.00	1600	BTAT803-63
	803	22.00	14.00	2591	BTAT803-102
	804	24.00	15.50	1600	BTAT804-63
	804	24.00	15.50	2591	BTAT804-102
	805	26.00	17.00	1600	BTAT805-63
	805	26.00	17.00	2591	BTAT805-102
	806	28.00	18.50	2591	BTAT806-102
807	30.00	20.00	2591	BTAT807-102	
i	803	0.866	0.551	63	BTAT803-63
	803	0.866	0.551	102	BTAT803-102
	804	0.945	0.610	63	BTAT804-63
	804	0.945	0.610	102	BTAT804-102
	805	1.024	0.669	63	BTAT805-63
	805	1.024	0.669	102	BTAT805-102
	806	1.102	0.728	102	BTAT806-102
	807	1.181	0.787	102	BTAT807-102

Section A30

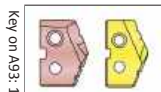

m = Metric (mm)
i = Imperial (in)



BT-A Drill Holders

3 Series | Diameter Range: 34.37 mm - 47.82 mm (1.3530" - 1.8829")

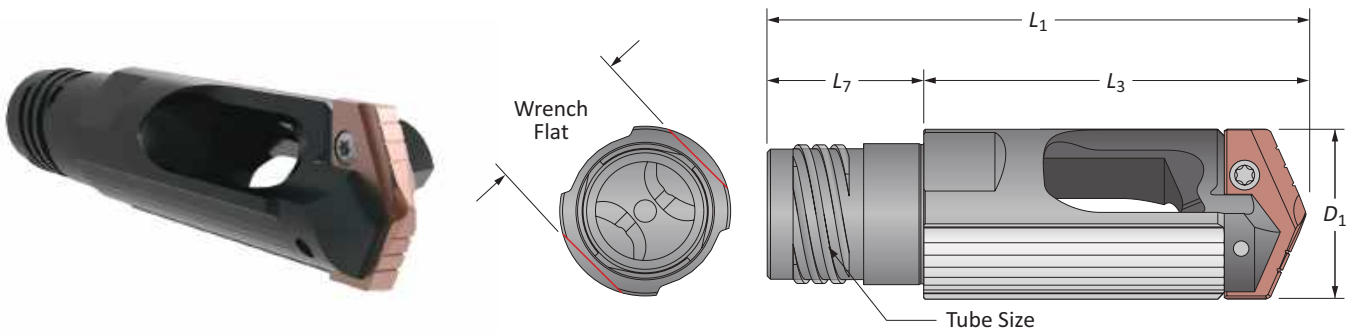

Tube Size	Holder					Part No.	T-A® Insert	Wrench Flat (mm)
	D ₁	L ₃	L ₁	L ₇				
m	807	34.37 - 36.22	96.8	132.8	36	BTA3-807-XX.XX	1C13H-XXXX-BT	30
	808	36.23 - 39.62	100.0	144.4	44.5	BTA3-808-XX.XX	1C13H-XXXX-BT	32
	809	39.63 - 43.00	103.1	146.2	43	BTA3-809-XX.XX	1C13H-XXXX-BT	36
	810	43.01 - 47.01	101.9	144.9	43	BTA3-810-XX.XX	1C13H-XXXX-BT	41
	811	47.02 - 47.82	103.2	146.2	43	BTA3-811-XX.XX	1C13H-XXXX-BT	41
i	807	1.3530 - 1.4259	3-13/16	5-15/64	1-27/64	BTA3-807-X.XXXX	1C13H-XXXX-BT	30
	808	1.4260 - 1.5599	3-15/16	5-11/16	1-3/4	BTA3-808-X.XXXX	1C13H-XXXX-BT	32
	809	1.5600 - 1.6929	4-1/16	5-3/4	1-11/16	BTA3-809-X.XXXX	1C13H-XXXX-BT	36
	810	1.6930 - 1.8509	4-1/64	5-45/64	1-11/16	BTA3-810-X.XXXX	1C13H-XXXX-BT	41
	811	1.8510 - 1.8829	4-1/16	5-3/4	1-11/16	BTA3-811-X.XXXX	1C13H-XXXX-BT	41

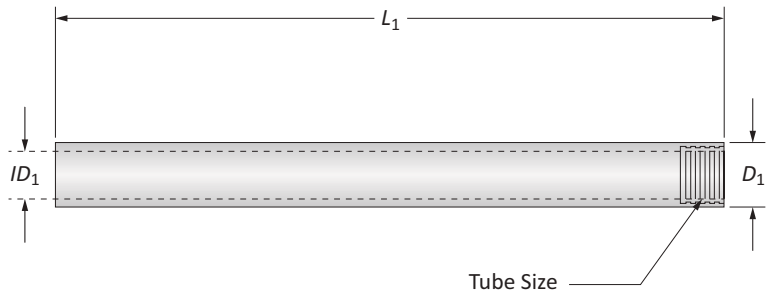

Tube Size	Tube			Part No.	
	D ₁	ID ₁	L ₁		
m	807	30.00	20.00	2591	BTAT807-102
	808	33.00	23.00	2591	BTAT808-102
	809	36.00	25.00	2591	BTAT809-102
	810	39.00	28.00	2591	BTAT810-102
	811	43.00	31.00	2591	BTAT811-102
i	807	1.181	0.787	102	BTAT807-102
	808	1.299	0.906	102	BTAT808-102
	809	1.417	0.984	102	BTAT809-102
	810	1.535	1.102	102	BTAT810-102
	811	1.693	1.220	102	BTAT811-102

Section A30

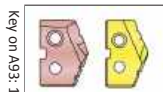

m = Metric (mm)
i = Imperial (in)

Drilling Guaranteed Application Form

*The following must be filled out completely before your test will be considered

CONTACT DETAILS

Trial P.O. No.* Date* Proposed Test Date*
 Favoured Distributor* Distributor Contact*
 Customer Name* Industry..... Contact Name*

APPLICATION INFORMATION

ATTENTION: The following Information is required to enable the best combination of tooling to be recommended. Please complete all that apply.

Material Type* Specification* Material Hardness Kg BRN RC N/mm²

Material Condition Flat Stock Round Stock Tubular Stock Plate
 Stacked Plate Hot Rolled Cold Rolled Casting Forging

Hole Diameter mm Inch Hole Depth..... Through Hole Blind Hole

Drilled Hole Tolerance Req'd Drilled Hole RMS Finished Req'd μInch μMetre

MACHINE SETUP

Machine Type Machining Centre Lathe Boring Mill
 Multi-spindle Auto Multi-spindle Drill Transfer Line
 Gantry Machine Dial Index Machine Radial Arm
 Gun Drilling Machine Pedestal Drill Other:

Machine Tool Builder* Model

Machine Tool Control* CNC NC Manual Other

Spindle Orientation* Vertical Horizontal Other

Machine Shank Required MAS BT DIN69871 HSK Spindle Taper Size 40 50 63 100 Other

Tool* Stationary Revolves

Available Power* KW HP Available Feed Trust Newtons Lbs

Available Speed* RPM M/min Variable Fixed

Preferred Shank Type* Flanged Morse Taper RCA Lathe Diameter mm Inch

Coolant Type* Cutting Oil Water Soluble Oil Air Mist Air Dry

Coolant Pressure* Bar PSI

Coolant Flow Rate* L/min GPM Coolant Supply Through Tool External

CURRENT DRILL INFORMATION

Drill Manufacturer Part Number

Drill Type Twist Brazed Indexable Insert Gun Drill
 Removable Tip Other

Tool Grade HSS Carbide Ceramic Other

Tool Coating Uncoated TiN TiCN TiAlN Other

Current Speed RPM M/min Current Feed Rate mm/rev mm/min

Average Number of Holes Drilled New After Regrind?

Reason(s) for Tool change Wear Fracture Chipping
 Losing Hole Tolerance Losing Chip Control Burr
 Other Chatter New Application

What criteria defines a successful test* Decreased Cycle Time Better Chip Control Safer Process
 Longer Tool Life Reduced Cost per Hole Other

Current Annual Usage €/: Current Tools per Annum?

*Required fields where applicable

FOR OFFICE USE ONLY

Application Engineer:

Number:

Status:

engineering.eu@alliedmachine.com

Allied Machine & Engineering Co. (Europe) Ltd
 93 Vantage Point, Pensnett Estate,
 Kingswinford, DY6 7FR, United Kingdom

+44 (0)1384 400 900
www.alliedmachine.com



ALLIED MACHINE
& ENGINEERING

WOHLHAUPTER

Holemaking Solutions for Today's Manufacturing

Warranty Information



Allied Machine & Engineering (“Allied Machine”) warrants to original equipment manufacturers, distributors, industrial and commercial users of its products for one year from the original date of sale that each new product manufactured or supplied by Allied Machine shall be free from defects in material and workmanship.

Allied Machine’s sole and exclusive obligation under this warranty is limited to, at its option, without additional charge, replacing or repairing this product or issuing a credit. For this warranty to be applied, the product must be returned freight prepaid to the plant designated by an Allied Machine representative and which, upon inspection, is determined by Allied Machine to be defective in material and workmanship.

Complete information as to operating conditions, machine, setup, and the application of cutting fluid should accompany any product returned for inspection. This warranty shall not apply to any Allied Machine products which have been subjected to misuse, abuse, improper operating conditions, improper machine setup or improper application of cutting fluid or which have been repaired or altered if such repair or alteration, in the judgement of Allied Machine, would adversely affect the performance of the product.

THIS WARRANTY IS IN LIEU OF ALL OTHER WARRANTIES, EXPRESS OR IMPLIED, INCLUDING ANY IMPLIED WARRANTY OF MERCHANTABILITY OR FITNESS FOR A PARTICULAR PURPOSE. Allied Machine shall have no liability or responsibility for any claim, whether in contract, tort or otherwise, for any loss or damage arising out of, connected with, or resulting from the manufacture, sale, delivery or use of any product sold hereunder, in excess of the cost of replacement or repair as provided herein.

Allied Machine shall not be liable in contract or in tort (including, without limitation, negligence, strict liability or otherwise) for economic losses of any kind or for any special, incidental, indirect, consequential, punitive or exemplary damages arising in any way out of the performance of, or failure to perform this agreement.

ALL PRICES, DELIVERIES, DESIGNS, AND MATERIALS ARE SUBJECT TO CHANGE WITHOUT NOTICE.



Allied Machine & Engineering Co. Europe Ltd. is registered to ISO 9001:2015 by bsi.



Allied Machine & Engineering is registered to ISO 9001:2015 by DQS.



Wohlhaupter GmbH is registered to ISO 9001:2015 by QUACERT.

Europe

Allied Machine & Engineering Co. (Europe) Ltd

93 Vantage Point
Pensnett Estate
Kingswinford
West Midlands
DY6 7FR England

Phone:

+44 (0) 1384 400 900

Wohlhaupter® GmbH

Maybachstrasse 4
Postfach 1264
72636 Frickenhausen
Germany

Phone:

+49 (0) 7022 408-0

United States

Allied Machine & Engineering

120 Deeds Drive
Dover OH 44622
United States

Phone:

+1.330.343.4283

Toll Free USA and Canada:

800.321.5537

Toll Free USA and Canada:

800.223.5140

Allied Machine & Engineering

485 W Third Street
Dover OH 44622
United States

Phone:

+1.330.343.4283

Toll Free USA and Canada:

800.321.5537

Asia

Wohlhaupter® India Pvt. Ltd.

B-23, 3rd Floor
B Block Community Centre
Janakpuri, New Delhi - 110058
India

Phone:

+91 (0) 11.41827044

Your local Allied Machine representative:

www.alliedmachine.com

Allied Machine & Engineering Co. Europe Ltd is registered to **ISO 9001:2015** by bsi.

Allied Machine & Engineering is registered to **ISO 9001:2015** by DQS.

Wohlhaupter GmbH is registered to **ISO 9001:2015** by QUACERT.

